

FULL COUPLING

ASME B16.11

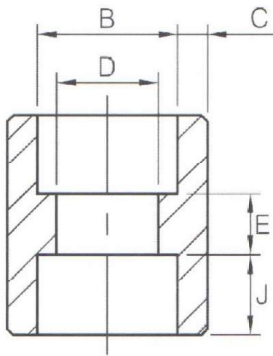

Dimensions in Millimeters.

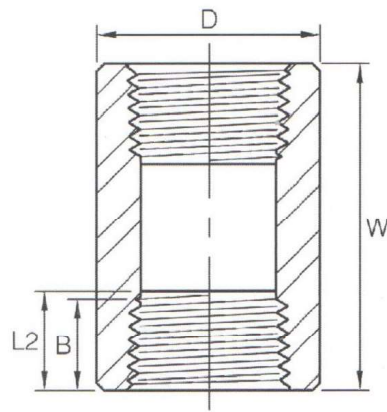

Dimensions in Millimeters.

Socket Welding							
DN	Nom. Pipe Size	B ⁽²⁾	C ⁽¹⁾		D ⁽²⁾	E ⁽²⁾	J (Min)
			(Avg)	(Min)			

3000Lb

6	1/8	10.8	3.18	3.18	6.9	6.5	9.5
8	1/4	14.2	3.78	3.30	9.3	6.5	9.5
10	3/8	17.6	4.01	3.50	12.6	6.5	9.5
15	1/2	21.8	4.67	4.09	15.8	9.5	9.5
20	3/4	27.2	4.90	4.27	21.0	9.5	12.5
25	1	33.9	5.69	4.98	26.7	12.5	12.5
32	1-1/4	42.7	6.07	5.28	35.1	12.5	12.5
40	1-1/2	48.8	6.35	5.54	40.9	12.5	12.5
50	2	61.2	6.93	6.04	52.5	19.0	16.0
65	2-1/2	73.9	8.76	7.67	62.7	19.0	16.0
80	3	89.8	9.52	8.30	78.0	19.0	16.0
100	4	115.2	10.69	9.35	102.3	19.0	19.0

6000Lb

6	1/8	10.8	3.96	3.43	4.0	6.5	9.5
8	1/4	14.2	4.60	4.01	6.4	6.5	9.5
10	3/8	17.6	5.03	4.37	9.2	6.5	9.5
15	1/2	21.8	5.97	5.18	11.8	9.5	9.5
20	3/4	27.2	6.96	6.04	15.6	9.5	12.5
25	1	33.9	7.92	6.93	20.7	12.5	12.5
32	1-1/4	42.7	7.92	6.93	29.5	12.5	12.5
40	1-1/2	48.8	8.92	7.80	34.0	12.5	12.5
50	2	61.2	10.92	9.50	42.9	19.0	16.0

9000Lb

15	1/2	21.8	9.35	8.18	6.4	9.5	9.5
20	3/4	27.2	9.78	8.56	11.1	9.5	12.5
25	1	33.9	11.38	9.96	15.2	12.5	12.5
32	1-1/4	42.7	12.14	10.62	22.8	12.5	12.5
40	1-1/2	48.8	12.70	11.12	28.0	12.5	12.5
50	2	61.2	13.84	12.12	38.2	19.0	16.0

(1) Average of socket Wall Thickness around periphery shall be no less than listed values. The minimum values are permitted in localized areas.

(2) Tolerance see page 16.

(3) Reducer : "C, J, E" in accordance with large size.
 "D" in accordance with small size.
 The others in accordance with each size.

Threaded					
DN	Nom. Pipe Size	Length of Thread. (Min)		W	D
		B ^(*)	L2 ^(*)		

3000Lb

6	1/8	6.4	6.7	32	16
8	1/4	8.1	10.2	35	19
10	3/8	9.1	10.4	38	22
15	1/2	10.9	13.6	48	28
20	3/4	12.7	13.9	51	35
25	1	14.7	17.3	60	44
32	1-1/4	17.0	18.0	67	57
40	1-1/2	17.8	18.4	79	64
50	2	19.0	19.2	86	76
65	2-1/2	23.6	28.9	92	92
80	3	25.9	30.5	108	108
100	4	27.7	33.0	121	140

6000Lb

6	1/8	6.4	6.7	32	22
8	1/4	8.1	10.2	35	25
10	3/8	9.1	10.4	38	32
15	1/2	10.9	13.6	48	38
20	3/4	12.7	13.9	51	44
25	1	14.7	17.3	60	57
32	1-1/4	17.0	18.0	67	64
40	1-1/2	17.8	18.4	79	76
50	2	19.0	19.2	86	92
65	2-1/2	23.6	28.9	92	108
80	3	25.9	30.5	108	127
100	4	27.7	33.0	121	159

(*) Dimension B is minimum length of perfect thread. The length of useful thread (B plus threads with fully formed roots and flat crests) shall not be less than L2 (effective length of external thread) required by American National Standard for pipe threads (ANSI / ASME B1.20.1) .