

# CLASS 1500 FLANGES

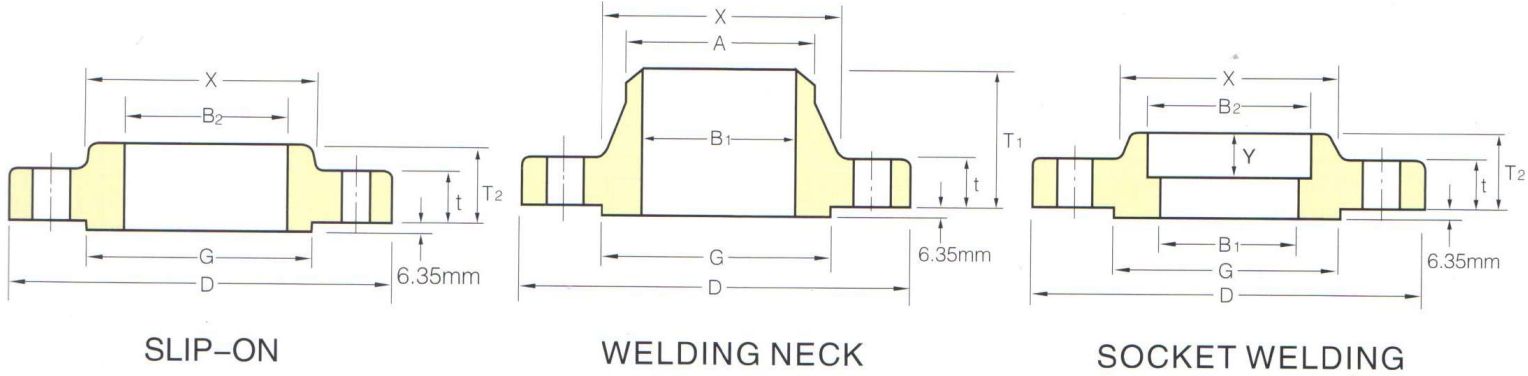

## ANSI B16.5 FORGED FLANGES

Unit:mm

Nominal Pipe Size	Outside Diam	Diam at Base of Hub	O.D. of Raised Face	Thick-ness	BORE				LENGTH THRU HUB			Diam. of Hub at Bevel	Radius of Fillet	Thread Length		
					Welding Neck Socket Welding	Slip-on Socket Welding	Lap Joint	Counter Bore Min	Welding Neck	Slip-on Threaded Socket Welding	Lap Joint					
					B1	B2	B3	B	T1	T2	T3				A	R
D	X	G	t													
1/2 3/4 1	121	38.1	35.1	22.4	See Note(1) To be specified by purchaser.		22.4	22.9	23.6	60.5	31.8	31.8	21.3	3.0	22.4	
	130	44.5	42.9	25.4			27.7	28.2	29.0	69.9	35.1	35.1	26.7	3.0	25.4	
	149	52.3	50.8	28.4			34.5	35.1	35.8	73.2	41.1	41.1	33.5	3.0	28.4	
1 1/4 1 1/2 2	159	63.5	63.5	28.4			43.2	43.7	44.5	73.2	41.1	41.1	42.2	4.8	30.2	
	178	69.9	73.2	31.8			49.5	50.0	50.5	82.6	44.5	44.5	48.3	6.4	31.8	
	216	104.6	91.9	38.1			62.0	62.5	63.5	101.6	57.2	57.2	60.5	7.9	38.1	
2 1/2	244	124.0	104.6	41.1			74.7	75.4	76.2	104.6	63.5	63.5	73.2	7.9	47.8	
	3	267	133.4	127.0		47.8		90.7	91.4	92.2	117.3	73.2	73.2	88.9	9.7	50.8
4	311	162.1	157.2	53.8				116.1	116.8	117.6	124.0	90.4	90.4	114.3	11.2	57.2
	5	375	196.9	185.7		73.2		143.8	144.5	144.5	155.4	104.6	104.6	141.2	11.2	63.5
6	394	228.6	215.9	82.6				170.7	171.5	171.5	171.5	119.1	119.1	168.4	12.7	69.9
	8	483	292.1	269.7		91.9		221.5	222.3	222.3	212.9	142.7	142.7	219.2	12.7	76.2
10 12 14	584	368.3	323.9	108.0			276.4	277.4	276.4	254.0	158.8	177.8	273.1	12.7	84.1	
	673	450.9	381.0	124.0			327.2	328.2	328.7	282.4	180.8	218.9	323.9	12.7	91.9	
	749	495.3	412.8	133.4			359.2	360.2	360.4	298.5	—	241.3	355.6	12.7	—	
16 18 20	826	552.5	469.9	146.1		410.5	411.2	411.2	311.2	—	260.4	406.4	12.7	—		
	914	596.9	533.4	162.1		461.8	462.3	462.0	327.2	—	276.4	457.2	12.7	—		
	984	641.4	584.2	177.8		513.1	514.4	512.8	355.6	—	292.1	508.0	12.7	—		
24	1168	762.0	692.2	203.2		616.0	616.0	614.4	406.4	—	330.2	609.6	12.7	—		

Notes:

- (1) For the inside diameter of pipes (corresponding to 'Bore'(B1) of Welding Neck Flanges), refer to page 33.
- (2) Class 1500 flanges except Lap Joint will be furnished with 0.25"(6.35mm) raised face, which is not included in 'Thickness' (t) and 'Length through Hub'(T1),(T2).
- (3) For Slip-on, Threaded, Lap Joint and Socket Welding Flanges, the hubs can be shaped either vertical from base to top or tapered within the limits 7 degrees.